

Hydronic Corporation

Air Driven Hydraulic Pumps and Intensifiers

P826 Installation, Use and Maintenance Manual

Contents

Introduction, Guarantee and Identification Plate

Description, Start Up Procedures

Description of Working Parts, Storage and Disposal

Fault Finding, Maintenance and Weights

Spare Parts

Hydronic Corporation, 32613 Folsom, Farmington Hills, MI 48336, United States of America

☎ (248) 477 2288, ☎ (248) 893 3689 www.hydroniccorp.com

Introduction

This handbook is intended to give the operator the basic instructions for the use and maintenance of the pump. The air hydraulic pump operator must read this handbook before putting the pump into operation. After correctly installing the pump, keep this manual stored in a safe place. If you have difficulty in understanding any part of this handbook, contact Hydronic Corporation. Regular servicing and correct use of the pump are fundamental in obtaining optimum performance over its life. When contacting our service center, specify the pump model and serial number. This will help us to respond quickly and effectively.

Guarantee

Hydronic pumps are guaranteed both for the quality of materials used and for overall design. The warranty runs for six months of normal use at eight hours per day and five days per week. The warranty itself does not cover seals or defects arising out of operating with unsuitable fluids or at pressures above the specified maximum. The guarantee cannot cover pumps that may have been tampered with. Defective goods must be sent to Hydronic Corporation at Farmington Hills or to the distributor covering the area, freight pre-paid in either case. Any pump returned to us must be accompanied by a full written description of such faults or defects as have been discovered. Please also ensure that the pump's serial number is attached to the paperwork.

Identification Plate

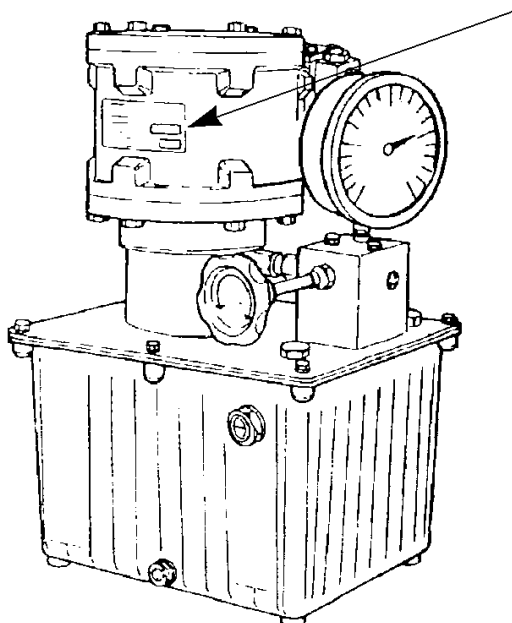

- 1 Model and ratio
- 2 Max oil pressure
- 3 Serial number
- 4 Max air pressure
- 5 Year

Installation Guide

Pumps should be installed in a vertical position for optimum functioning of suction and delivery valves. The recommended minimum size for the suction line is 3/8" bore, for the pressure line is 1/4" bore and for the airline is 1/2" bore. It is also recommended that pumps should be used with a hydraulic directional control valve. The following standard conditions are advised:

- Hydraulic oil having viscosity of 150 to 250 SSU
- Oil temperature 32° F to 150° F
- Air temperature 40° F to 120° F
- Room temperature 40° F to 120° F

Obstructive icing of the silencer may occur under certain temperature/humidity conditions. This can be remedied by the addition of antifreeze oil for pneumatic equipment to a mist lubricator.

Compressed Air System

It is strongly recommended that an air filter/regulator/gauge unit having minimum flow capacity of 50 scfm is fitted in order to ensure the pump has sufficient air energy to work correctly and provide the hydraulic performance you expect.

Hydraulic System

Valves, pipes, hoses and accessories should all correspond to maximum working pressure of the pump used and be of a size that will fulfill flow requirements. Bear in mind the minimum of 3/8" bore for the suction line.

Application

Hydronic air driven hydraulic pumps are designed for operating oil hydraulic circuits and to cover the widest range of requirements to the best advantage. The pump itself operates quite simply, using a well known pressure intensification principle. A piston with a large surface area is actuated by compressed air. Attached to it is a piston with a smaller surface area and driven in a hydraulic chamber generating a high level of hydraulic pressure. The continuous pumping action is produced by the compressed air being switched by a special valve assembly and timing mechanism. By regulating the compressed air supply pressure from 20 psi to 100 psi, the maximum hydraulic pressure can be adjusted by the ratio of the pump used. As the hydraulic load of the circuit increases and the oil pressure rises, the pump will slow down and eventually stop. In this way, the maximum load of the circuit will be maintained without air consumption.

Storage

If the pump is to be kept out of use for a long period, clean the pump in general and drain the oil from the tank. Cover the pump and store it in a dry, well-protected place. It is advisable to wrap the pump in a plastic film. To put back into service, check all parts, fill tank with oil and try the pump out to ensure that it working properly. **Qualified personnel must carry out this operation.**

Disposal

If the pump is to be scrapped, treat as a special type of waste. Dismantle it and divide it into materials of the same type and dispose of them in accordance with the local laws and regulations in the your state or area.

Description of the standard pump components

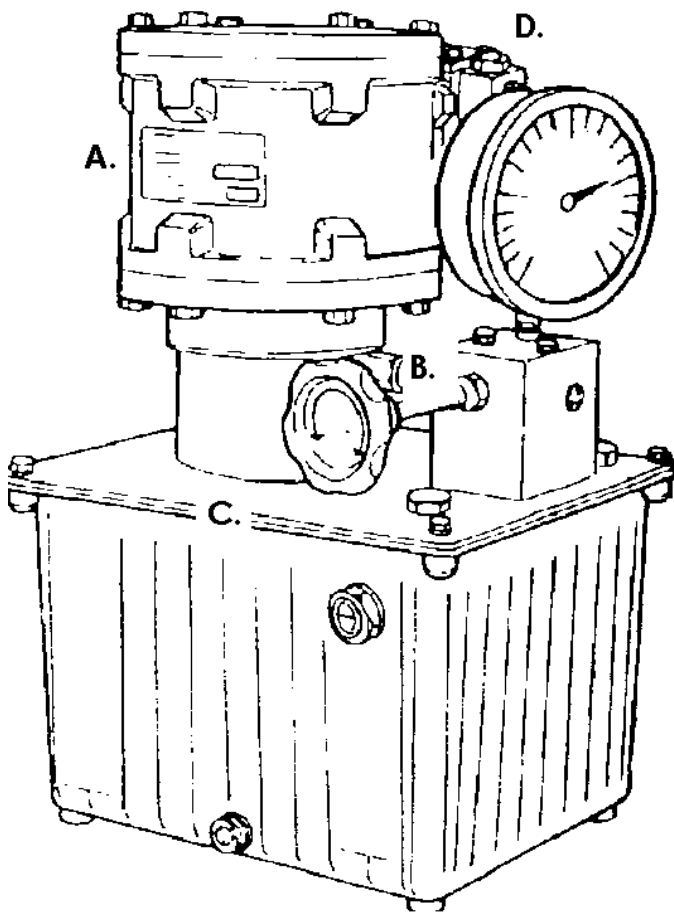

A Air inlet 1/2" NPT

B Oil outlet

1:65 ratio #8 SAE

1:120 ratio 3/4-16 HP threads

1:170 ratio 3/4-16 HP threads

1:265 ratio 3/4-16 HP threads

1:345 ratio 3/4-16 HP threads

C Oil suction

D Air Exhausts

Starting - Up

Oil pressure can be determined by regulation of the inlet compressed air pressure and bearing in mind the multiplication ratio pre-selected for the pump itself.

The models are:	P826-65	RATIO 1:65
	P826-120	RATIO 1:120
	P826-170	RATIO 1:170
	P826-265	RATIO 1:265
	P826-345	RATIO 1:345

It should be remembered that the action of the air/oil piston assembly is powered in both directions by the compressed air. The single acting oil piston causes the suction of oil through the suction valve only when the piston assembly is traveling upward. When the piston assembly is traveling downward, oil is pushed out into the system through the output check valve.

Having connected the compressed air supply at a low pressure (perhaps only 20 psi), allow the pump to operate slowly until fully primed and a steady flow of oil comes through to the output port. Now shut off the air supply to the pump and securely connect the rest of the hydraulic circuit to the outlet port. Switch on the air supply again and allow the pump to run in order to bleed any air out of the rest of the hydraulic circuit. The system pressure can then be adjusted by means of the air regulator.

Fault Finding Chart

<u>Fault</u>	<u>Cause</u>	<u>Remedy</u>
1] Pump does not cycle or runs slowly.	1.1] Low pressure in compressed air line. 1.2] Formation of ice on the exhaust side. 1.3] Accumulation of waste in the silencer. 1.4] Blocked element in air filter/regulator.	1.1] Clear any blockage or restriction on the air line. 1.2] Shut off pump for a short time and drain off water from the filter. 1.3] Remove silencer, clean and replace. 1.4] Close down air-supply, dismantle and clean filter.
2] Pump loses air from silencer when stalled.	2.1] Worn valve or seal	2.1] Replace seal or valve.
3] Excess oil leakage from air silencer.	3.1] Worn hydraulic seal	3.1] Replace seal.

4] Pump cycles without pumping oil.	4.1] Blocked suction.	4.1] Clean out filter.
	4.2] Bad connection on suction line.	4.2] Check for bad connections or air leaks on suction line.
	4.3] Low oil level	4.3] Refill oil, check for leaks.
5] Pump functions but only generates low pressure and does not stall at maximum oil Pressure.	5.1] Internal leakage in the circuit.	5.1] Find leak source and change valve.
	5.2] Suction valve seats damaged and leaking.	5.2] Replace suction valve parts.
	5.3] Output valve seats damaged and leaking.	5.3] Replace output valve parts.
	5.4] Worn oil seal.	4.4] Replace seal.

Maintenance

Periodically release the condensation from the air filter. Replace the hydraulic oil every 1,500 hours or whenever the oil is polluted.

Warning: Remember that repair work can only be made when pneumatic and hydraulic pressure has been released and you are sure that no pressure remains in the circuit.

Delivery of the pump

Transport

All the material shipped, including the detached parts, has been thoroughly checked before being consigned to the forwarding agent. The pump is shipped in double corrugated cardboard packaging which assures protection of the product.

Unpacking

On receipt of the product, open the packaging and remove the pump. Take care not to damage any part of the pump. Make an initial check on the pump for damage in transit. In case of damage or if in doubt, do not use the pump and contact Hydronic Corporation or your distributor. The packaging [plastic bags, expanded polystyrene, nails, screws, wood, etc.] must not be left within reach of children since they are potential source of danger. Be sure to dispose of pollutant or non-biodegradable materials in the correct way. Materials must be disposed of in accordance with the local, national and ecological laws in force.

Gross weight

P826 Basic pump of any ratio 27.1 lbs, 12.3 kgs.

Contents of the package

The packaging will always contain the following:

- 1 x air driven hydraulic pump
- 1 x installation, use and maintenance manual

Original spare parts

Parts orders must always be accompanied by the following information:

- A] The pump model B] The pump serial number C] The pump year of construction
(all this data is given on the nameplate)
- D] The part numbers E] The quantity required F] The name of the part
(All this data is given in the parts list)

A clear and correct statement of this data will allow our after-sales service to respond quickly and appropriately. Professionally qualified staff must install every spare part. The manufacturer declines all responsibility for malfunctions or accidents deriving from any failure of the product when unqualified persons have made any attempt at repair.

Item	Code	Description	Qty
1	3.094.0208	Screw	12
2	5.086.0006	Head	1
3	* 3.051.0075	O-Ring	2
4	* 3.051.0076	Seal Ring	2
5	3.045.0204	Self-Locking Nut	1
6	5.034.0014	Piston	1
7	5.018.0030	Jacket	1
8	5.068.0193	Piston	1
8	5.068.0116	Piston	1
8	5.068.0115	Piston	1
8	5.068.0114	Piston	1
8	5.068.0113	Piston	1
9	* 3.051.0083	O-Ring	2
10	5.084.0002	Plug	2
11	5.086.0007	Pneumatic Head	1
13	* 7.078.0011	345:1 Hp Seal Kit	1
13	* 7.078.0013	265:1 Hp Seal Kit	1
13	* 7.078.0014	170:1 Hp Seal Kit	1
13	* 7.078.0015	120:1 Hp Seal Kit	1
13	* 7.078.0016	65:1 Hp Seal Kit	1
15	5.033.0014	Valve Seat	1
16	3.076.0013	Ball	1
17	5.046.0017	Centering Ball	1
18	5.064.0022	Spring	1
19	5.071.0025	Outlet Connector	1
20	7.078.0032-12	Pilot Valve	1
21	3.094.0224	Screw	4
22	5.028.0065	345:1 Pump Body	1
22	5.028.0055	265:1 Pump Body	1
22	5.028.0054	170:1 pump Body	1
22	5.028.0053	120:1 Pump Body	1
22	5.028.0052	65:1 Pump Body	1
25	5.046.0014	345:1, 265:1, 170:1 Centering Ball	1
25	5.046.0015	120:1 & 65:1centering Ball	1
26	5.064.0023	Spring	1
27	3.076.0004	Ball	1
28	5.071.0024	Suction Connector	1
31	3.072.0104	Washer	12
32	* 3.051.0077	O-Ring	2
33	5.045.0017	345:1 & 265:1ring-Nut	1
33	5.045.0018	170:1ring-Nut	1
33	5.045.0019	120:1ring-Nut	1
33	5.045.0020	65:1ring-Nut	1
34	* 3.051.0080	O-Ring	1
61	* 3.051.0082	O-Ring	2
62	* 3.051.0002	O-Ring	2
72	3.094.0018	Screw	3

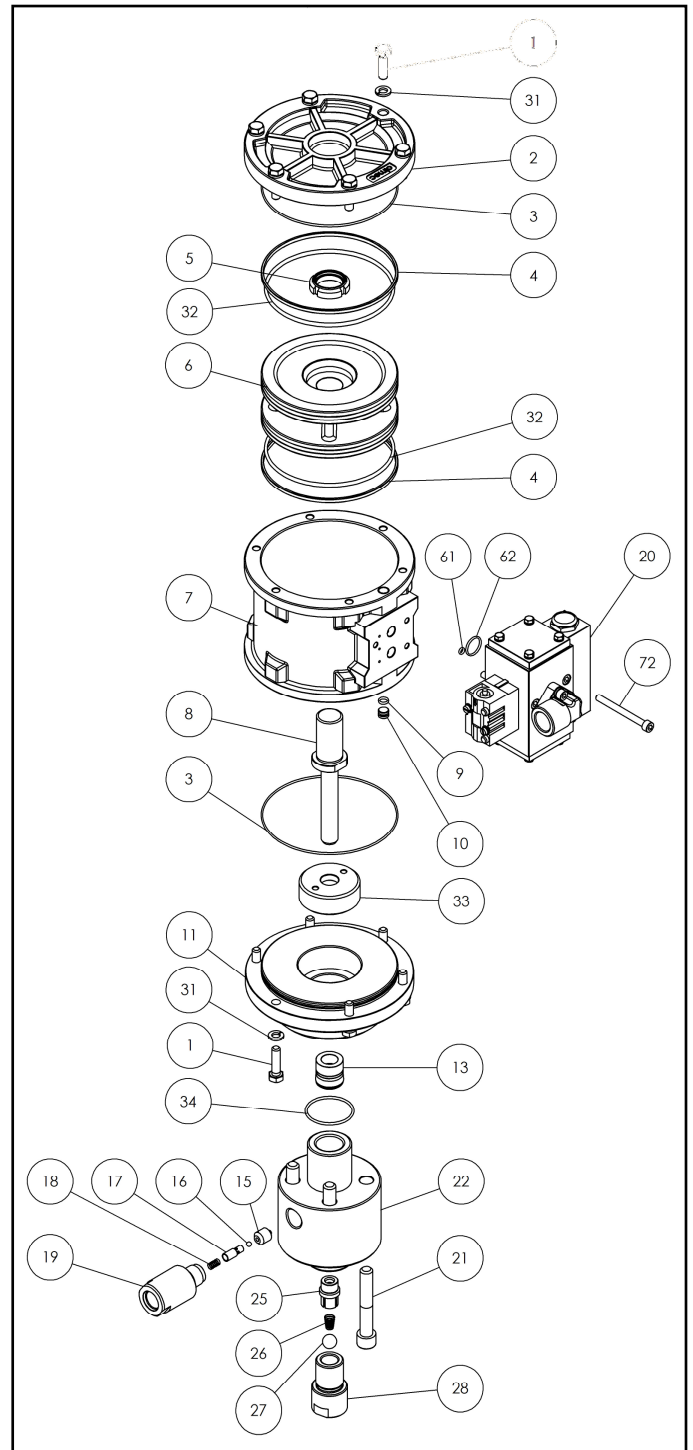

Old Air Valve

Item	Code	Description	Qty
52	3.094.0206	Screw	8
53	3.072.0102	Washer	10
54	5.027.0001	Cover	2
55	* 3.051.0080	O-Ring	2
56	5.008.0013	Disk	2
57	* 3.051.0081	O-Ring	6
59	7.078.0118	Distributor Pivot + Bushing	1
60	5.028.0026	Valve Body	1
61	* 3.051.0082	O-Ring	2
62	* 3.051.0002	O-Ring	2
63	3.072.0103	Washer	3
64	3.070.0068	Silencer	2
65	4.091.0002	Pilot Valve	1
66	3.094.0227	Screw	2
66/1	3.072.0101	Washer	3
66/2	3.072.0001	Washer	3
67	5.065.0014	Silencer Body	1
68	3.094.0205	Screw	2
69	* 3.051.0025	O-Ring	1
70	3.070.0005	Connector	1
71	3.094.0008	Screw	3
72	3.094.0018	Screw	3

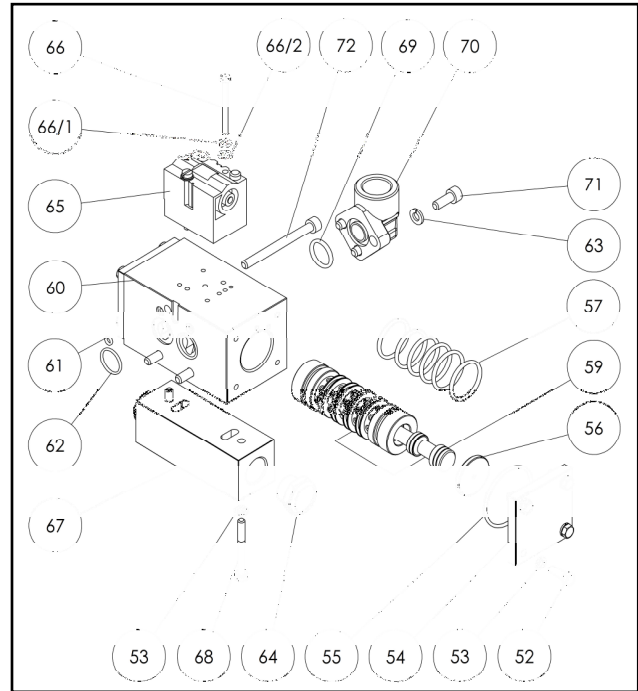

New Air Valve

ITEM	CODE	DESCRIPTION	Qty
1	5.065.0052	BLOCK	1
2	* 3.051.0109	O-RING	2
3	* 3.051.0130	O-RING	8
4	3.094.0026	SCREW	3
5	4.091.0020	POWER VALVE	1
6	4.091.0028	PILOT VALVE	1
7	3.094.0061	SCREW	3
8	3.070.0096	SILENCER	1
9	3.070.0068	SILENCER	1
10	3.070.0028	PLUG	2

Seal Kits For Complete Overhaul:	Ratio
* 3.054.0097	345:1
* 3.054.0038	265:1
* 3.054.0037	170:1
* 3.054.0036	120:1
* 3.054.0043	65:1

